

70LP

TANDEM AXLE LOW PROFILE DUMP

G.V.W.R.	7,000#
G.A.W.R. (EA. AXLE)	3,500#
COUPLER	7K 2" Bulldog
SAFETY CHAINS	¼" Grd. 70 w/ Safety Latch Hook (2 ea.)
JACK	2000# Top Wind (Bolted On)
TONGUE	5" Channel
FRAME	5" Channel
CROSSMEMBERS	3" X 3" Square Tubing
BED CROSSMEMBERS	2" X 2" Square Tubing
BED LONG SILS	3" Channel
BED SIDE RAILS	3" X 5" Formed Angle
FENDERS	9" X 72" Teardrop
AXLES	Two 3500# Cambered Axles w/ Elec. Brakes
SUSPENSION	Multi-Leaf Spring w/ Equalizer
TIRE	ST205/75-15 Load Range C
WHEEL	15 X 6 White Spoke 5 Bolt
FLOOR	12 Ga. Smooth Steel
LIGHTS	D.O.T. Stop, Tail, Turn and Clearance
ELEC. PLUG	6 Way
FINISH (PREP)	Acid Etched w/White Phosphorus, Undercoated w/Panther 813 & Two Coats Primer
FINISH	Painted w/ 2 Coats High Solid <i>Supreme</i> Acrylic Automotive Grade Enamel, and Pinstriped

STANDARD FEATURES

- Complete Break-A-Way System w/ Charge Line
- 45 Degree Dump Angle
- 1 Piece 12 Ga. Floor
- Protected Lighting
- Self Contained Electric Hydraulic Scissor Lift
- Enclosed Pump & Battery Box Mounted In Front of Bed
- Lockable Control Unit
- 1 Piece 2 Way Style Rear Gate
- 1/2" Tie Rail On All 4 Sides
- 14 Stake Pockets (Sides & Front)
- 18" X 12 Ga. Sides w/ Formed Channel Supports

70LP-10

<i>DIMENSIONS</i>			
LENGTH	A	B	C
10'	120"	55-1/2"	64-1/2"

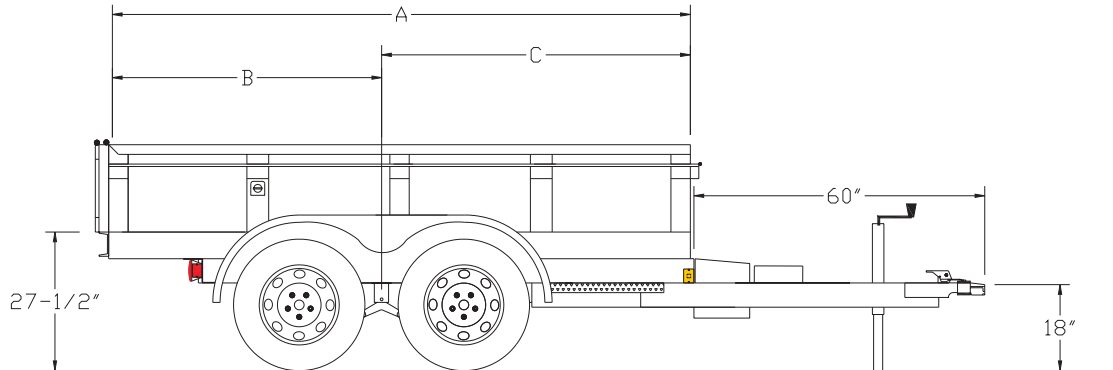

TRAILER WEIGHTS & CAPACITIES

LENGTH	EMPTY WEIGHT	BOX CAPACITY
10'	2,110#	2.5 Yards

OPTIONS

HYD2	Hydraulic Brakes on 2 Axles w/ Toledo Actuator
DRG	Double Rear Gate
SP	15" Spare Tire & Wheel – Load Range C
SPMT	Spare Tire Mount (Side)
AP	Adjustable Pintle In Channel

Effective January 1, 2003 (Specifications and Options subject to change without notice.)