

50DS

SINGLE AXLE LOW PROFILE DUMP

G.V.W.R.	5,000#	AXLE	5200# Cambered Axle w/ Elec. Brake
G.A.W.R.	5,080#	SUSPENSION	Multi-Leaf Spring
COUPLER	7K 2" Bulldog	TIRE	ST225/75-15 Load Range D
SAFETY CHAINS	¼" Grd. 70 w/ Safety Latch Hook (2 ea.)	WHEEL	15 X 6 White Spoke 6 Bolt
JACK	2000# Top Wind (Bolted On)	FLOOR	12 Ga. Smooth Steel
TONGUE	5" Channel	LIGHTS	D.O.T. Stop, Tail, Turn and Clearance
FRAME	5" Channel	ELEC. PLUG	6 Way
CROSSMEMBERS	3" X 3" Square Tubing	FINISH (PREP)	Acid Etched w/White Phosphorus, Undercoated w/Panther 813 & Two Coats Primer
BED CROSSMEMBERS	2" X 2" Square Tubing	FINISH	Painted w/ 2 Coats High Solid <i>Supreme</i> Acrylic Automotive Grade Enamel, and Pinstriped
BED LONG SILS	3" Channel		
BED SIDE RAILS	3" X 5" Formed Angle		
FENDERS	9" X 36" Radius' d		

STANDARD FEATURES

- Complete Break-A-Way System w/ Charge Line
- 18" x 12 Ga. Sides w/Formed Supports
- 1 Piece 12 Ga. Floor
- Self Contained Electric / Hydraulic Scissor Lift
- Enclosed Pump & Battery Box Mounted In Front of Bed
- Lockable Control Unit
- Protected Lighting
- 1 Piece 2 Way Style Rear Gate
- 1/2" Tie Rail On All 4 Sides
- 14 Stake Pockets (Sides & Front)
- 40 Degree Dump Angle

50DS-10

DIMENSIONS			
LENGTH	A	B	C
10'	120"	54"	66"

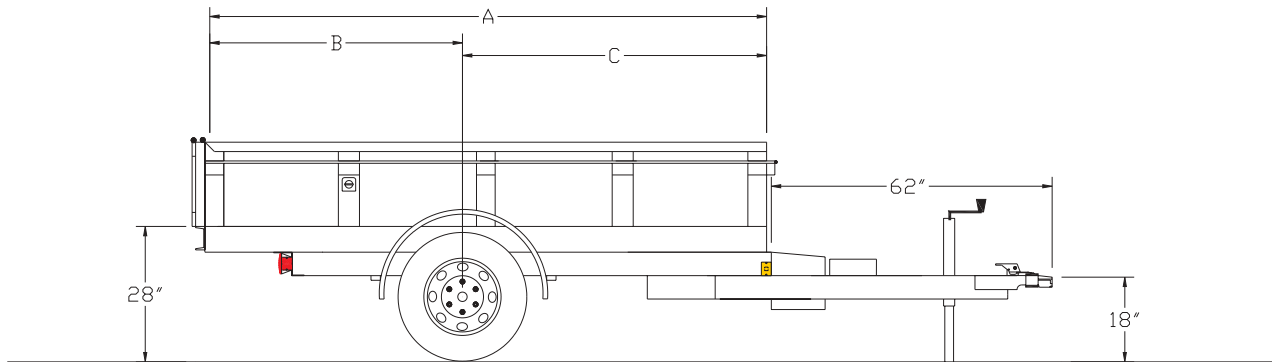

TRAILER WEIGHTS & CAPACITIES

LENGTH	EMPTY WEIGHT	BOX CAPACITY
10'	1,850#	2.5 Yards

OPTIONS

HYD1	Hydraulic Brakes on 1 Axle w/ Toledo Actuator
DRG	Double Rear Gate
SP	15" Spare Tire & Wheel – Load Range D
SPMT	Spare Tire Mount (Side)
AP	Adjustable Pintle In Channel

Effective January 1, 2003 (Specifications and Options subject to change without notice.)