

# 30SA / 35SA

## SINGLE AXLE UTILITY TRAILER

<b>G.V.W.R.</b>	2,995#	<b>AXLE</b>	3500# Axle w/ Brake Flanges
<b>G.A.W.R.</b>	2,960#	<b>SUSPENSION</b>	Multi-Leaf Spring
<b>COUPLER</b>	2" A-Frame	<b>TIRE</b>	ST205/75-15 Load Range B
<b>SAFETY CHAINS</b>	1/4" Grd. 30 w/Safety Latch Hook (2 ea.)	<b>WHEEL</b>	15 x 5 White Spoke 5 Bolt
<b>JACK</b>	2000# Top Wind (Bolted On)	<b>FLOOR</b>	2" Pine
<b>TONGUE</b>	3" Channel Tongue	<b>LIGHTS</b>	D.O.T. Stop, Tail, Turn and Clearance
<b>TOP RAIL</b>	2-3/8" Pipe Square Back	<b>ELEC. PLUG</b>	4 Way Flat w/ Loom
<b>FRAME</b>	2" X 3" X 3/16" Angle	<b>FINISH (PREP)</b>	Acid Etched w/White Phosphorus, Undercoated w/Panther 813 & Two Coats Primer
<b>CROSSMEMBERS</b>	2" X 3" X 3/16" Angle	<b>FINISH</b>	Painted w/ 2 Coats High Solid <i>Supreme</i> Acrylic Automotive Grade Enamel, and Pinstriped
<b>UPRIGHTS</b>	15" Tall 2" X 2" X 1/8" Angle		
<b>FENDERS</b>	9" X 32" Rolled Formed w/ Back		

### STANDARD FEATURES

- 3500# Idler Axle w/Flanges for Easy Brake Addition
- Bar & Pockets Across Back
- Safety Chains Attached w/ Cold Rolled Eyelets
- Top Rail Capped w/ Self Sealing Plugs
- Lower Jack Support Plate
- Floor Secured w/ 5/16" Torx Screws
- 2-3/8" Pipe Top Rail

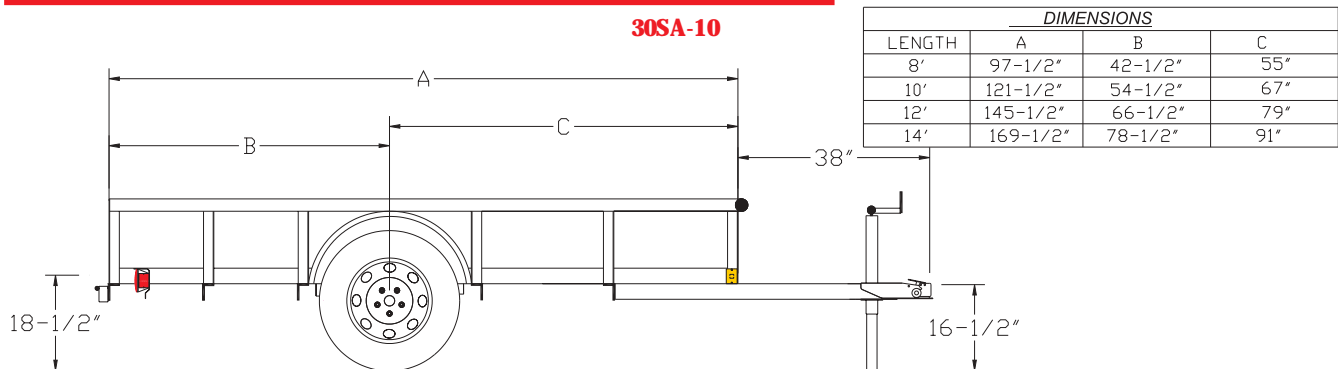

### OPTIONS

<b>BRK1</b>	Electric Brakes On One Axle ( Includes complete break--a-way System )
<b>RG</b>	Rampgate for 30SA / 4' Tall
<b>RG</b>	Rampgate for 35SA / 4' Tall
<b>SPMT</b>	Spare Tire Mount (Side)
<b>SP</b>	15" Spare Tire & Wheel - Load Range B
<b>BD2</b>	2" Bulldog Coupler
<b>FUJ</b>	2K Fold-Up Jack
<b>SBJ</b>	Set Back Jack
<b>HSS</b>	Higher Side (Ea. Additional Foot )
<b>ENEX</b>	Enclosed w/ Expanded Metal (Per Sq. Ft.)
<b>ENSH</b>	Enclosed w/ Sheet Metal (Per Sq. Ft.)
<b>VTT</b>	V-Tongue Tilt
<b>SAR</b>	Shock Assist option for Rampgate
<b>CH</b>	Car Hauler Style (Includes 6 Stake Pockets)
<b>STPK</b>	Tie Down Pockets (Ea.)

Effective January 1, 2003 (Specifications and Options subject to change without notice.)