

# 14GD

## TANDEM AXLE LOW PROFILE GOOSENECK DUMP

<b>G.V.W.R.</b>	14,000#	<b>AXLES</b>	Two 7000# Cambered Axles w/ Elec. Brakes
<b>G.A.W.R. (EA. AXLE)</b>	6,084#	<b>SUSPENSION</b>	Multi-Leaf Slipper Spring w/ Equalizer
<b>COUPLER</b>	2-5/16" Standard Adjustable Pipe	<b>TIRE</b>	LT235/85-16 Load Range E
<b>SAFETY CHAINS</b>	3/8" Grd. 70 w/Safety Latch Hook (2 ea.)	<b>WHEEL</b>	16 X 6 HD White Modular 8 Bolt
<b>JACK</b>	10,000# Dropleg (Bolted On)	<b>FLOOR</b>	12 Ga. SmoothSteel
<b>NECK</b>	8" Channel	<b>LIGHTS</b>	D.O.T. Stop, Tail, Turn and Clearance
<b>FRAME</b>	8" Channel	<b>ELEC. PLUG</b>	6 Way
<b>CROSSMEMBERS</b>	6" Channel + 3" X 3" Tubing	<b>FINISH (PREP)</b>	Acid Etched w/White Phosphorus, Undercoated w/Panther 813 & Two Coats Primer
<b>BED CROSSMEMBERS</b>	2" X 2" Tubing	<b>FINISH</b>	Painted w/ 2 Coats High Solid <i>Supreme</i> Acrylic Automotive Grade Enamel, and Pinstriped
<b>BED LONG SILS</b>	4" Channel		
<b>BED SIDE RAILS</b>	4" X 6" Angle		
<b>FENDERS</b>	14 Ga. Diamond Plate Double Broke Teardrop		

### STANDARD FEATURES

- Complete Break-A-Way System w/ Charge Line
- 36" 12 Ga. Sides w/ Formed Channel Supports
- 1 Piece 12 Ga. Floor
- 45 Degree Dump Angle
- Enclosed Pump & Battery Box Mounted In Front of Bed
- Lockable Control Unit
- Protected Lighting
- Double Rear Gates w/ Cam Latch
- 1/2" Tie Rail On All 4 Sides
- Fully Self Contained Electric Hydraulic Scissor Lift

14GD-14

LENGTH	DIMENSIONS		
	A	B	C
12'	144"	65"	79"
14'	168"	65"	103"

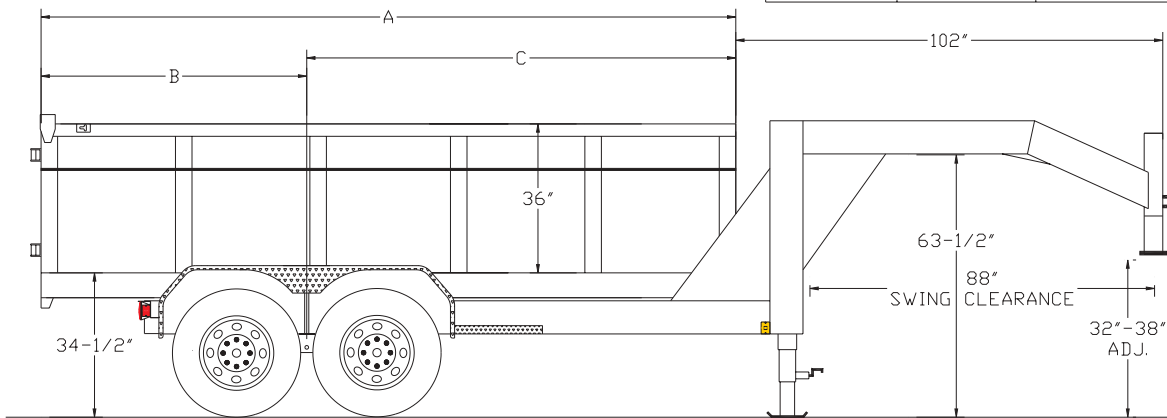

### TRAILER WEIGHTS & CAPACITIES

LENGTH	EMPTY WEIGHT	BOX CAPACITY
12'	4,700#	7.9 Yards
14'	4,950#	9.2 Yards

### OPTIONS

<b>SP</b>	16" Spare Tire & Wheel - Load Range E
<b>SR7</b>	7' Slide In Ramps
<b>TU</b>	16" Tire upgrade to Load Range G
<b>SPU</b>	16' Spare Tire & Wheel - Load Range G

Effective January 1, 2003 (Specifications and Options subject to change without notice.)