

# 10LP

## TANDEM AXLE LOW PROFILE DUMP

<b>G.V.W.R.</b>	9,990#	<b>AXLES</b>	Two 5200# Cambered Axles w/ Elec. Brakes
<b>G.A.W.R. (EA. AXLE)</b>	5,080#	<b>SUSPENSION</b>	Multi-Leaf Spring w/ Equalizer
<b>COUPLER</b>	Adjustable 2-5/16" Bulldog	<b>TIRE</b>	7.50 X 16" Load Range E
<b>SAFETY CHAINS</b>	1/4" Grd. 70 w/ Safety Latch Hook (2 ea.)	<b>WHEEL</b>	16 X 6 White Spoke 6 Bolt
<b>JACK</b>	2000# Top Wind (Bolted On)	<b>FLOOR</b>	12 Ga. Smooth Steel
<b>TONGUE</b>	6" Channel	<b>LIGHTS</b>	D.O.T. Stop, Tail, Turn and Clearance
<b>FRAME</b>	6" Channel	<b>ELEC. PLUG</b>	6 Way
<b>CROSSMEMBERS</b>	4" - 13# I-Beam	<b>FINISH (PREP)</b>	Acid Etched w/White Phosphorus, Undercoated w/Panther 813 & Two Coats Primer
<b>BED CROSSMEMBERS</b>	2" X 2" Square Tubing	<b>FINISH</b>	Painted w/ 2 Coats High Solid <i>Supreme</i> Acrylic Automotive Grade Enamel, and Pinstriped
<b>BED LONG SILS</b>	4" Channel		
<b>BED SIDE RAILS</b>	3" X 6 1/2" Formed Angle		
<b>FENDERS</b>	16 Ga. Smooth Double Broke Teardrop		

### STANDARD FEATURES

- Complete Break-A-Way System w/ Charge Line
- 24" 12 Ga. Sides w/ Formed Channel Supports
- 1 Piece 12 Ga. Floor
- Protected Lighting
- Self Contained Electric Hydraulic Scissor Lift
- Enclosed Pump & Battery Box Mounted In Front of Bed
- Lockable Control Unit
- Double Rear Gates w/ Cam Latch
- 1/2" Tie Rail On All 4 Sides
- 14 Stake Pockets (Sides & Front)
- 45 Degree Dump Angle
- Removable Header Across Rear

10LP-10

DIMENSIONS			
LENGTH	A	B	C
10'	120"	55-1/4"	64-3/4"
12'	144"	49-1/4"	94-3/4"

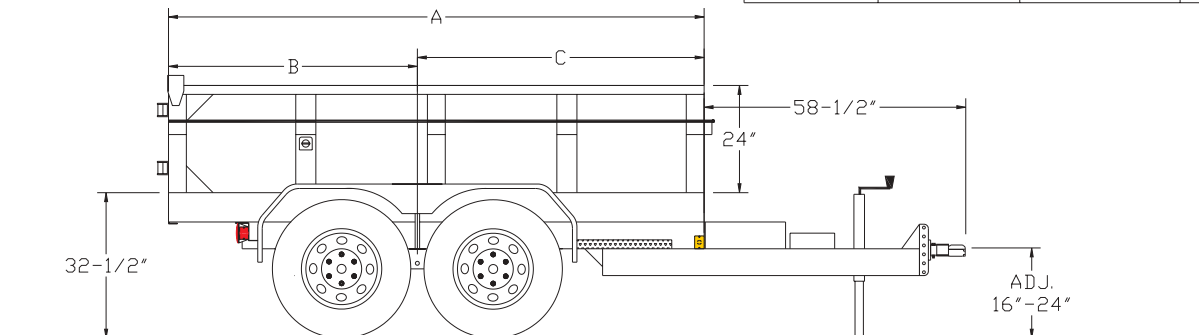

### TRAILER WEIGHTS & CAPACITIES

LENGTH	EMPTY WEIGHT	BOX CAPACITY
10'	3,040#	4.4 Yards
12'	3,400#	5.7 Yards

### OPTIONS

<b>HYD2</b>	Hydraulic Brakes on 2 Axles, 2-5/16" w/ Adjustable Demco Actuator
<b>DLJ</b>	7K Top Wind Drop Leg Jack
<b>SP</b>	16" Spare Tire & Wheel - Load Range E
<b>SPMT</b>	Spare Tire Mount (Side)
<b>SR7</b>	7' Slide In Ramps
<b>AP</b>	Adjustable Pintle In Channel

Effective January 1, 2003 (Specifications and Options subject to change without notice.)